

A=1.280,00m²

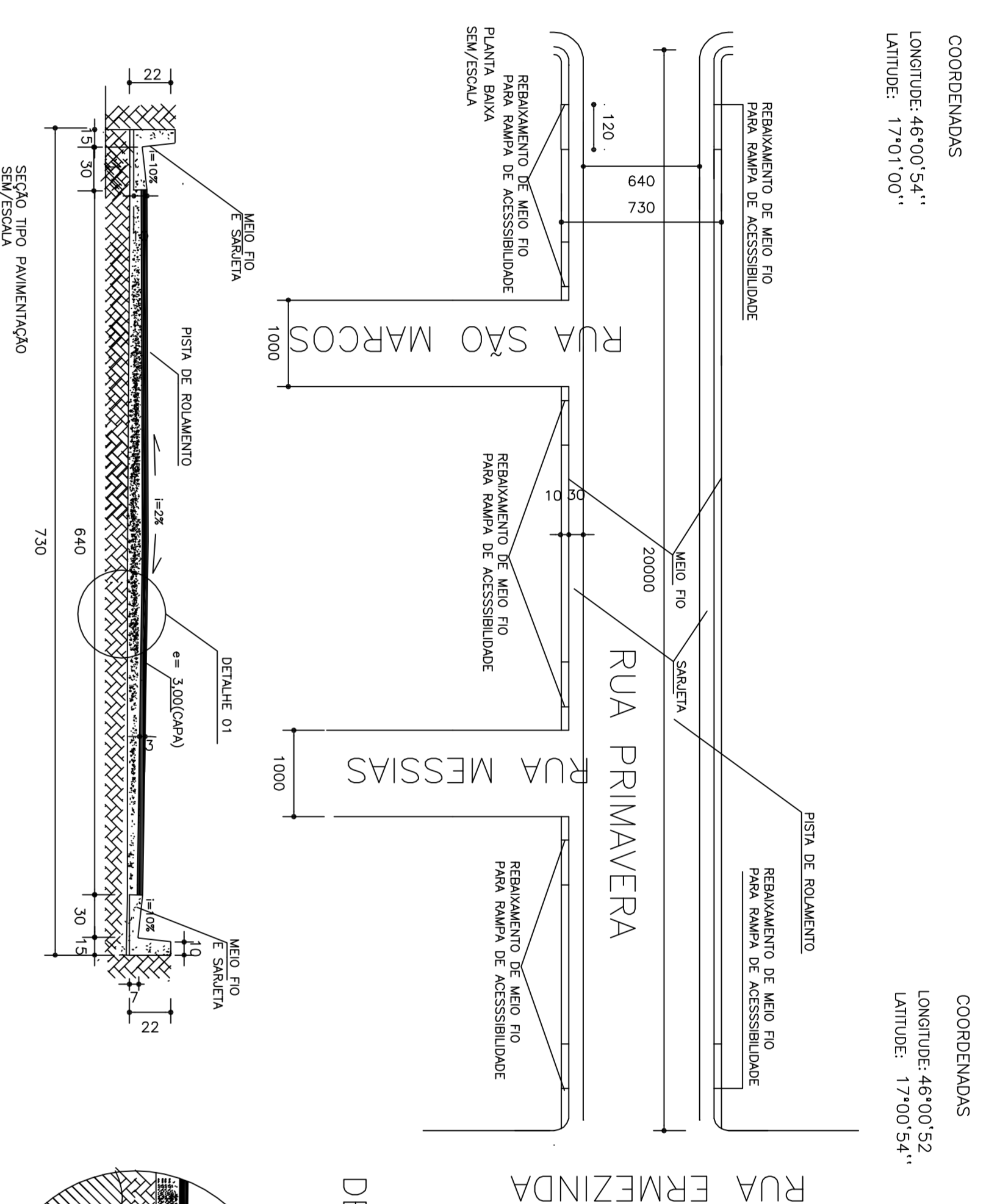

DETALHE - 01

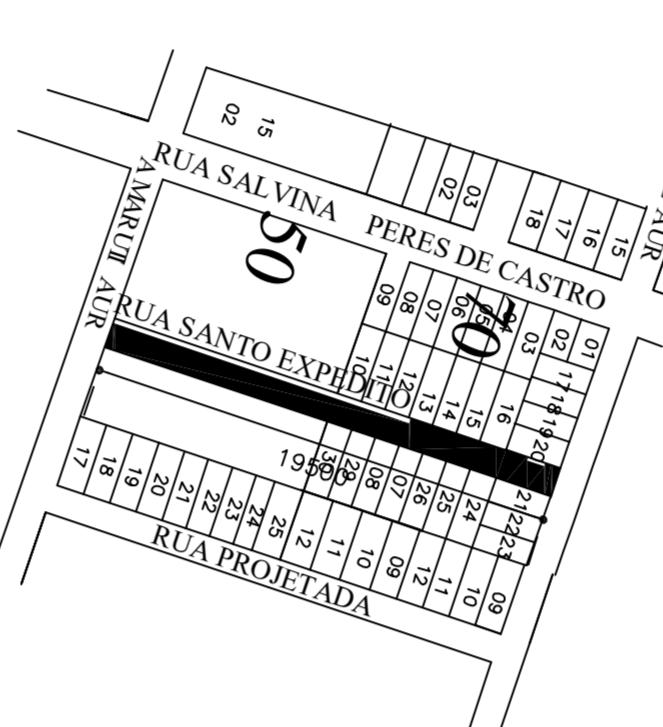
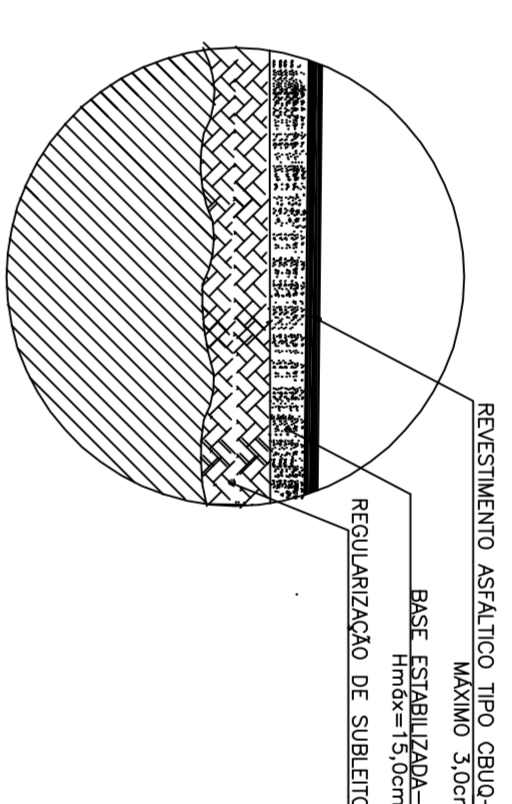

A=1.053,00m²

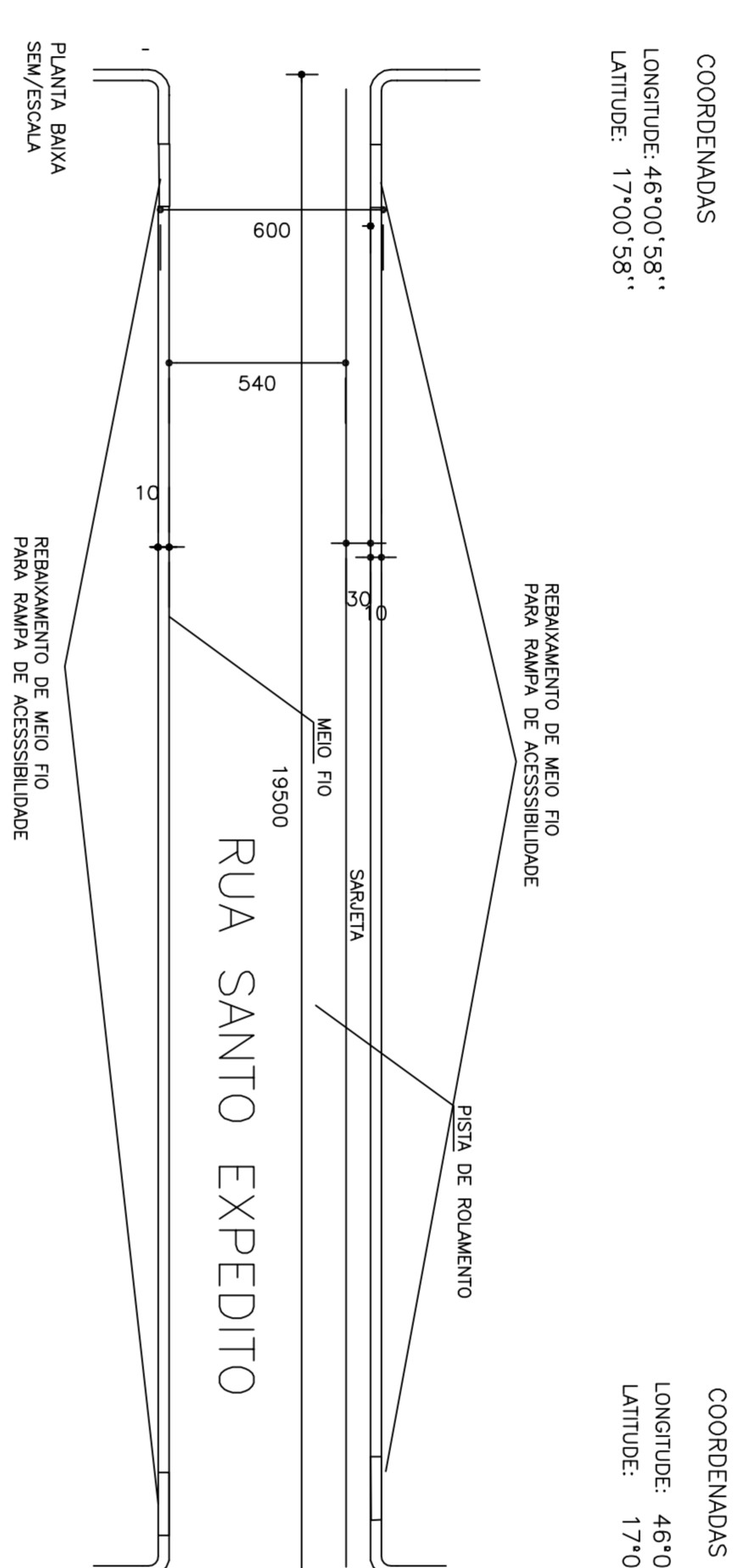

DETALHE - 01

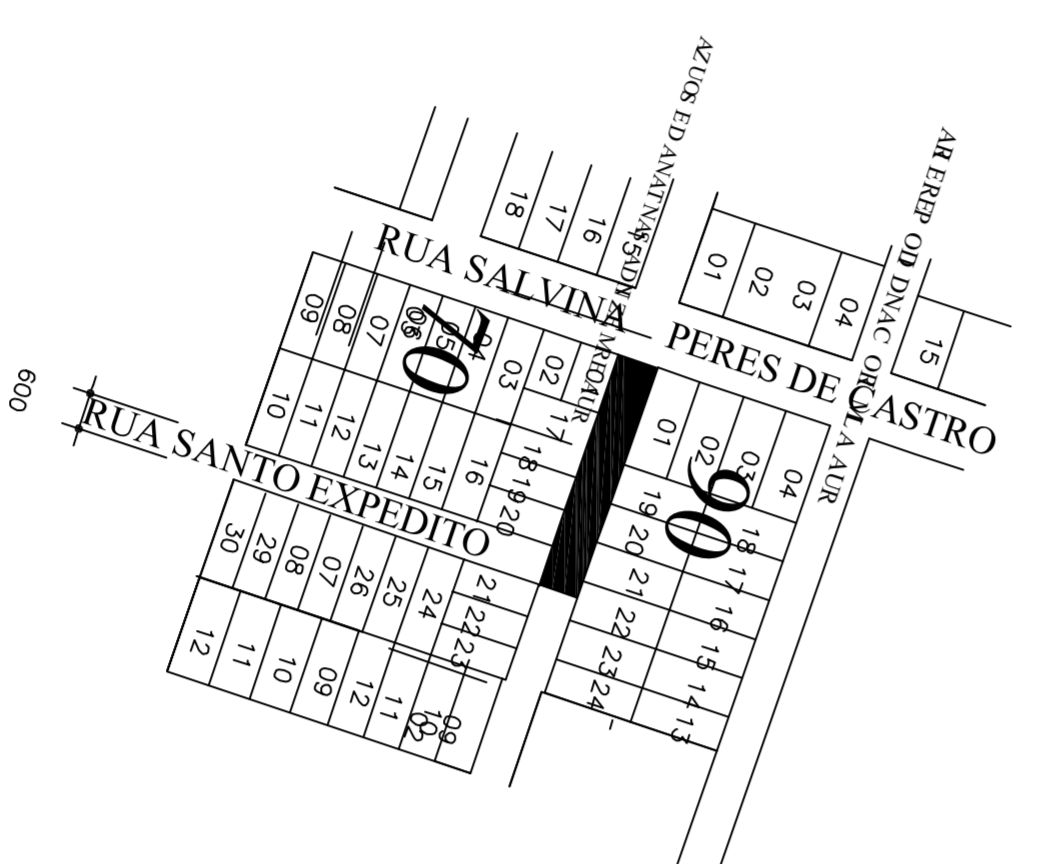
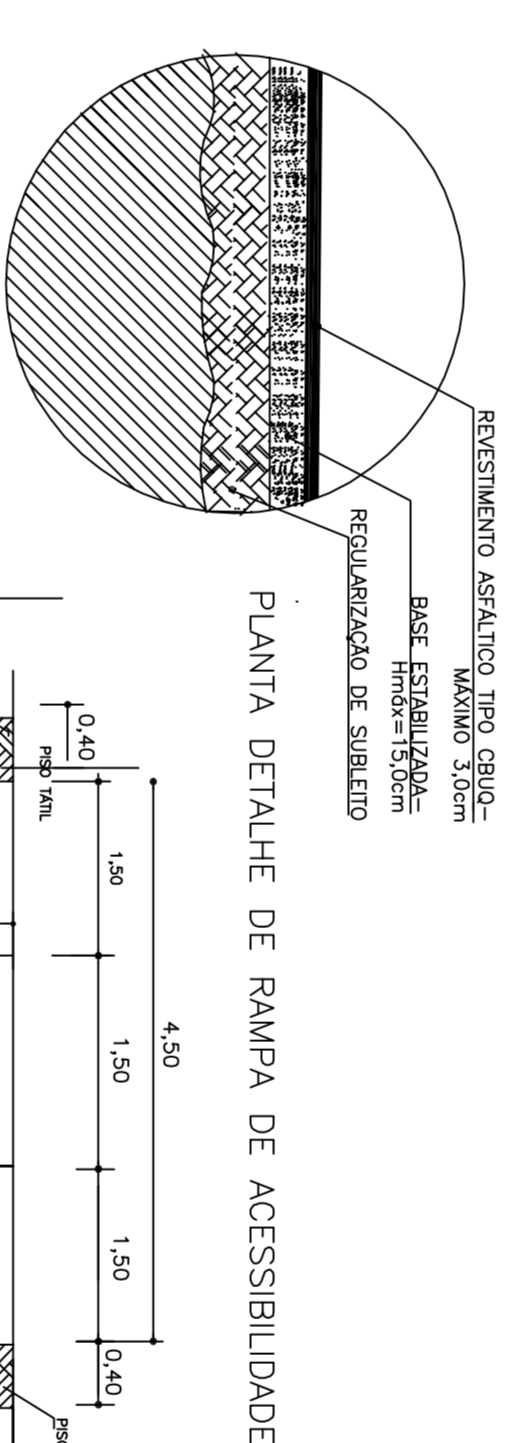
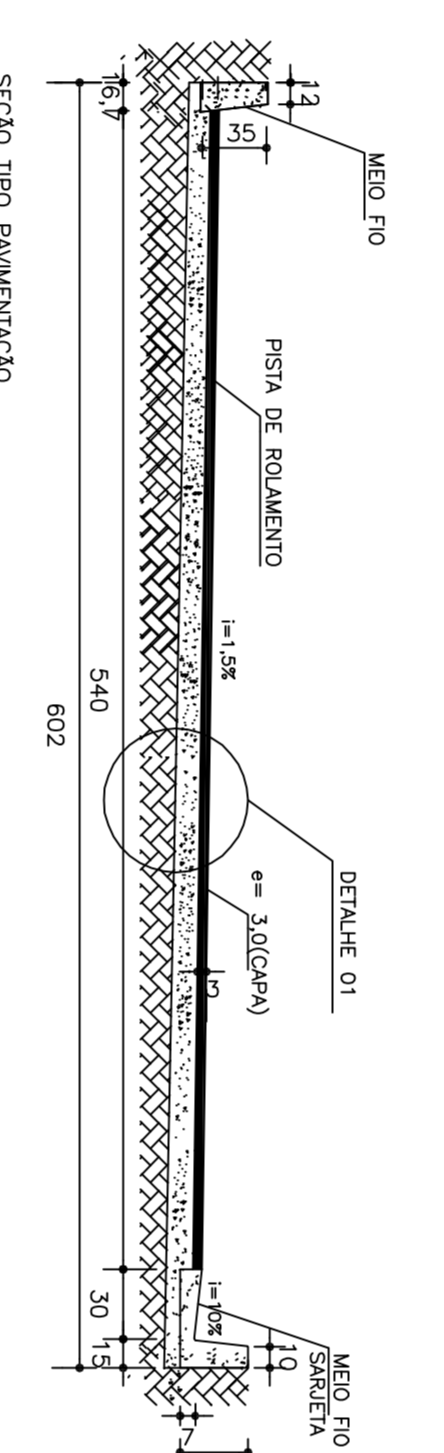

A=388,80m²

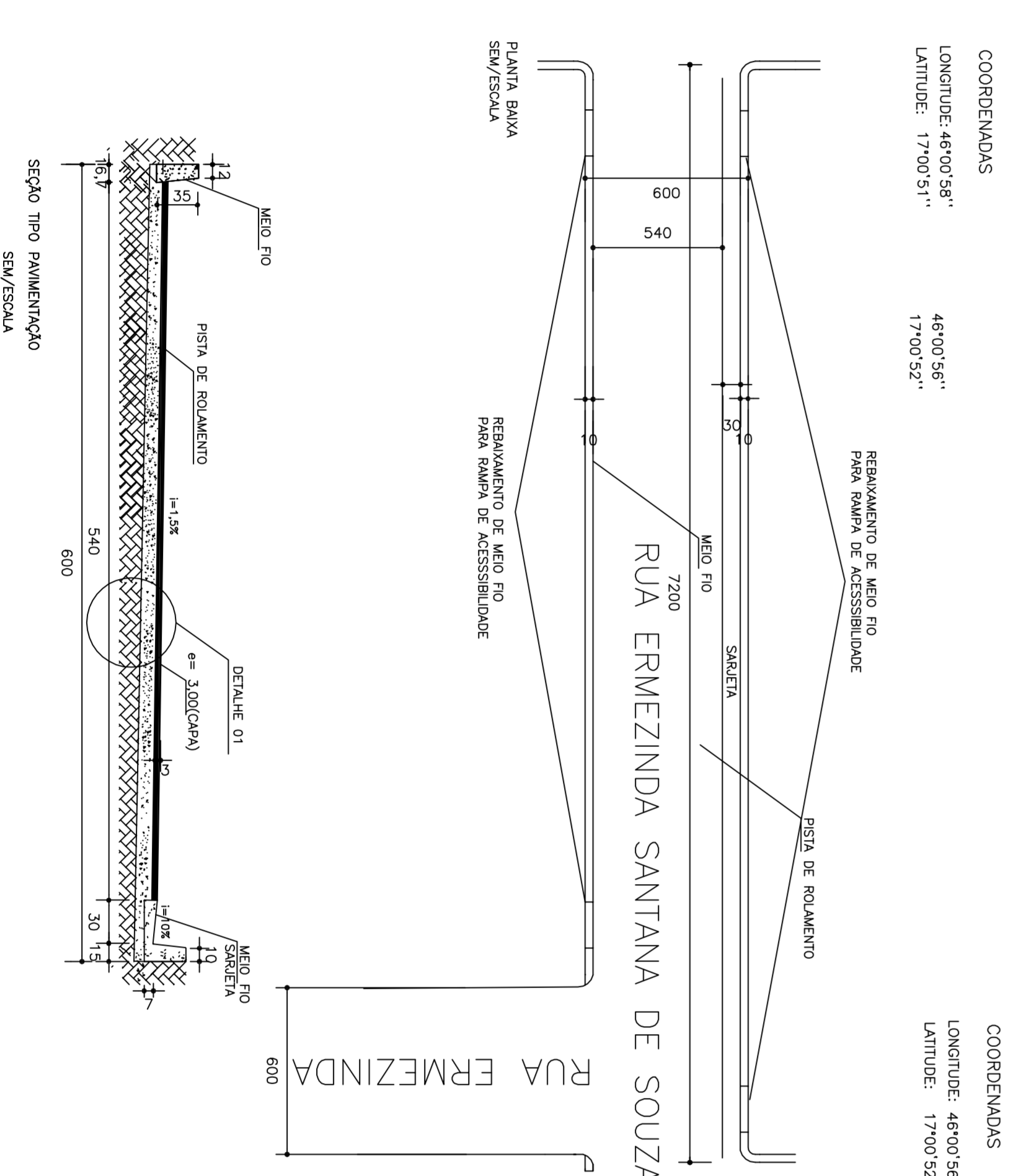

DETALHE - 01

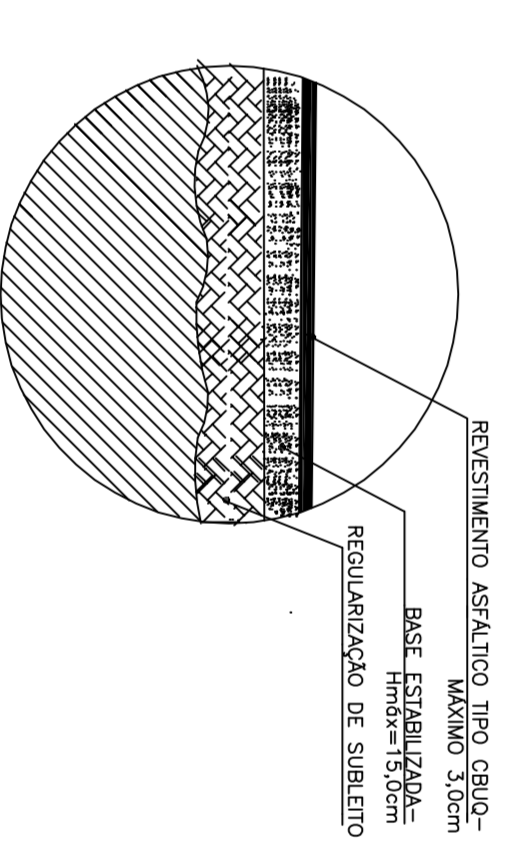

CIDADE: BRASILÂNDIA DE MINAS – MG
 ENDEREÇO: RUA PEDRO LAURINDOURUA FAUSTINO FERNANDES, RUA JOSÉ MOREIRA E RUA AUGUSTO TIMOTEO DE OLIVEIRA
 PROPRIETÁRIO: PREFEITURA MUNICIPAL DE BRASILÂNDIA DE MINAS – MG
 AUTOR DO PROJETO: JOÃO EVANGELISTA DE MATOS NUNES-CEKA 61.277-0-MG
 RESP.TÉCNICO: CEKA

PROPRIETÁRIO: PREFEITURA MUNICIPAL DE BRASILÂNDIA DE MINAS-MG
 AUTOR PROJETO: JOÃO EVANGELISTA DE MATOS NUNES CEKA:61.277-0-MG
 RESP. TÉCNICO: CEKA

LEGENDA:	
RUA S A PAVIMENTAR	
Áreas	DIVERSOS
Lote	DIVERSAS
Quadrante	PORTO
Barragem	2.721,80M²
Área e Reservas:	

PROJETO DE PAVIMENTAÇÃO ASFALTICA EM CBUQ e=3cm

PREF.MUNIC:DE BRASILÂNDIA DE MINAS

Contém: PLANTA BAIXA E DETALHES

Folho 01/02

outubro/2023

Escala: Indecida